



CUBEX LTD. PRODUCT UPDATE

BULLETIN: PU-0015

DATE: JUNE 10, 1993

SUBJECT: BOOSTER INLET ASSEMBLY CM48300-ARR

INFORMATION: Cubex has reconfigured and enlarged the inlet assembly to our boosters.

The larger mine air filter improves overall partical filtration, but the advance is in water separation. With its much deeper body the filter prevents water, that has already been separated from the air, from being agitated and reintroduced into the stream. The result is better valve life and less water contamination of compressor oil.

The inlet size is 3" instead of 2". This results in less pressure drop from the line to booster. Therefore, inlet pressure at the booster is higher, the result is more production of sir and less heat generation.

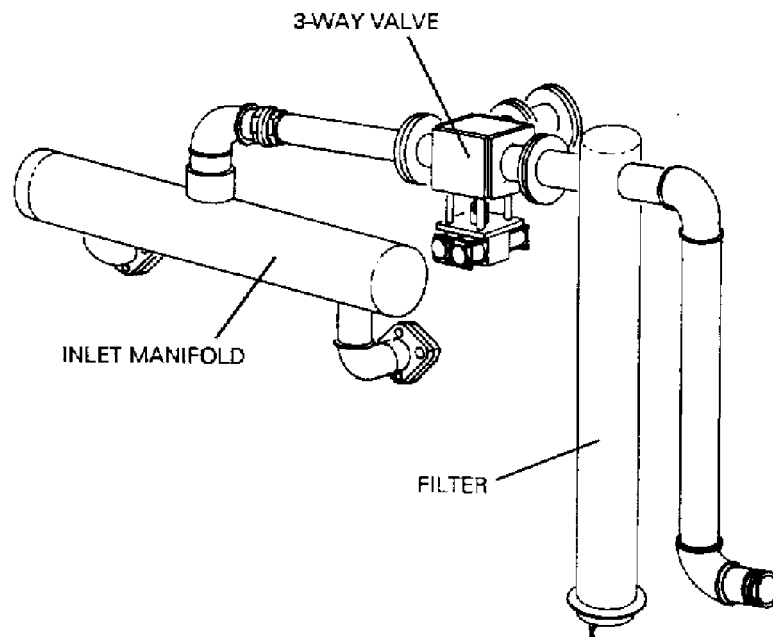

For further information contact your local Cubex Ltd. Representative.